

HIGH-TRO-REEL
SYSTEM CODIGO

PCHTR

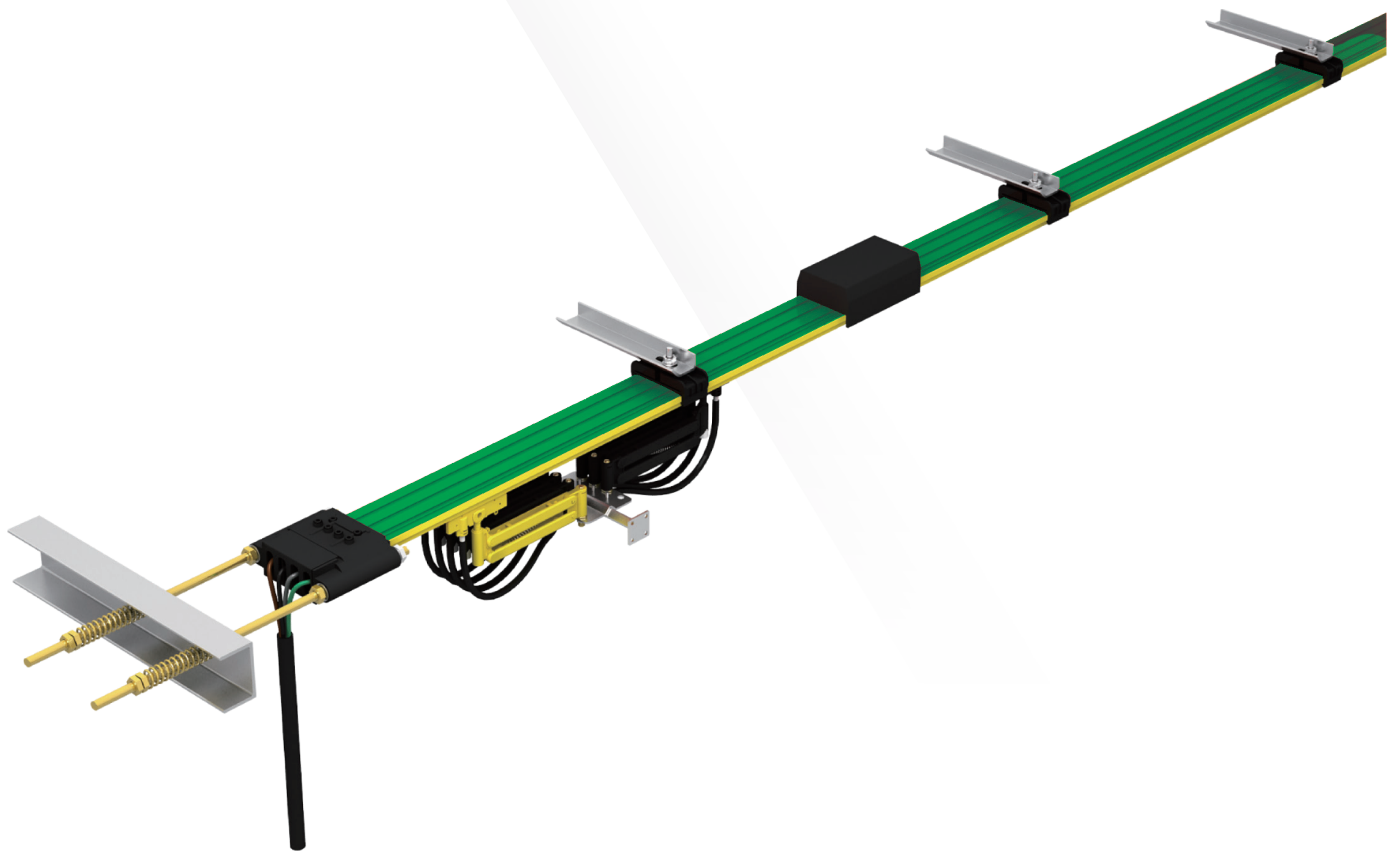



Introduction of products

With PCHTR, unmanned factory, increasing the degree of automation of the device, the minuaturation of the conductor rail system, ease of installation, high-speed stability is extremely important. To meet the needs of market development, we has successfully developed the PCHTR series seamless conductor rail system, the system has the following advantages, run smoothly, high speed, low noise, powered way arbitrariness.

Contents

- INSTALLATION VIEW OF PCHTR SYSTEM
- TYPE OF PCHTR CONDUCTOR SYSTEM
- HANGER CLAMP & JOINTING BOX (LINE FEEDING)
- COLLECTOR & TOWING BRACKET
- END TENSIONER (END FEEDING), TOWING ARM & CARBON BRUSH
- INSTALLATION TECHNICAL PARAMETERS (SUPPORT BRACKET)
- HANGER INSTALLATION & SPECAIL INSTALLATION
- INSTALLATION OF END TESIONER (END FEEDING)
- INSTALLATION OF JOINTING BOX (LINE FEEDING)
- INSTALLATION OF COLLECTOR & MAINTENANCE

Installation view

- Supply 1000m conductor without any joint.
- Installation easily and quickly. Offer 3P, 4P (35A, 50A, 65A, 80A, 100A, 120A, 140A), 6P (50A, 80A) total three types, with the load matching, selection and utilization economically. Meanwhile 3P, 4P can be combined into other types.

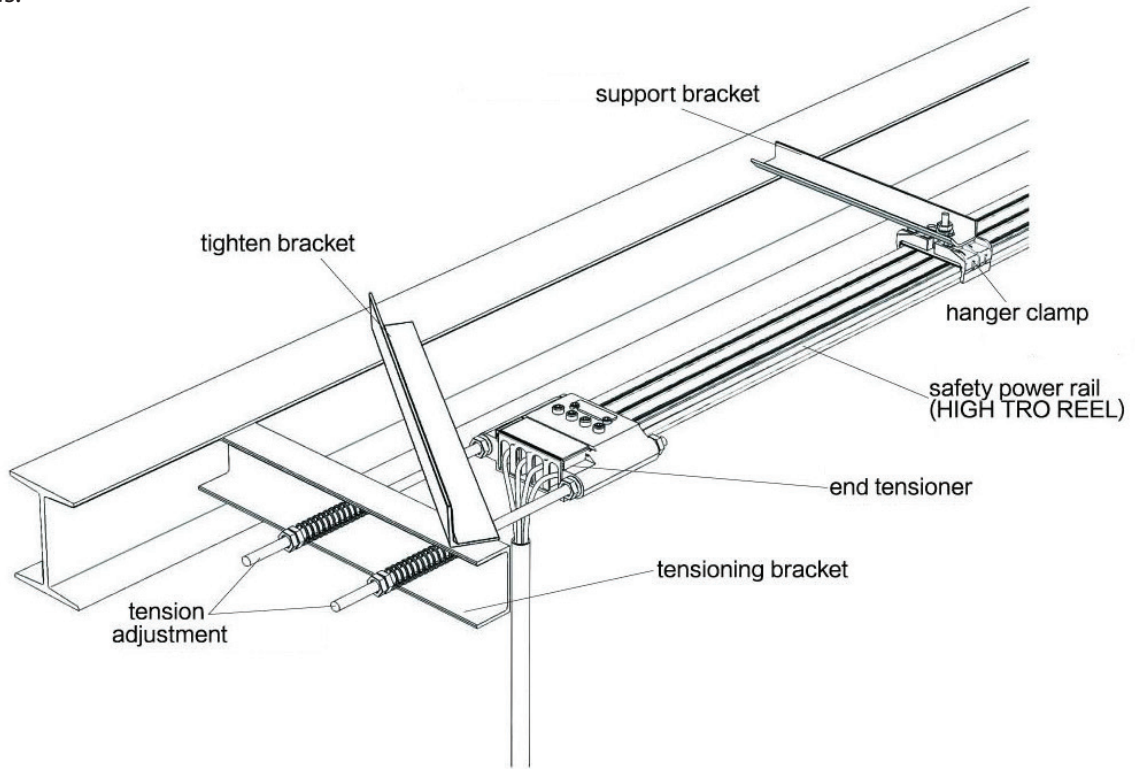

Standard installation

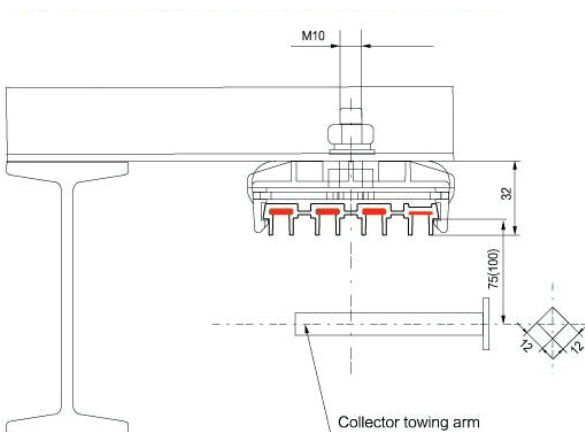

Horizontal installation

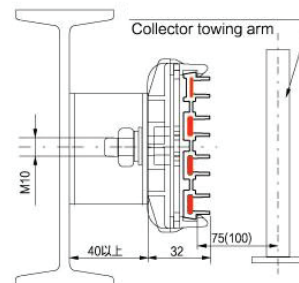

Vertical installation

PCHTR4502KPA body (indoor only)

Rating: 4P, 690V, 50A-120A

Conductor material: cooper

Insulation jacket material: rigid PVC (heat resistance: 75°C)

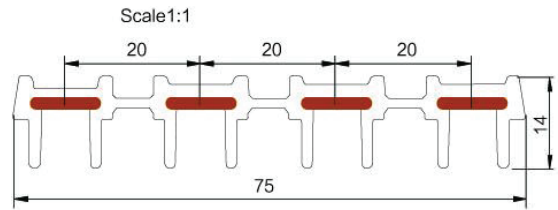
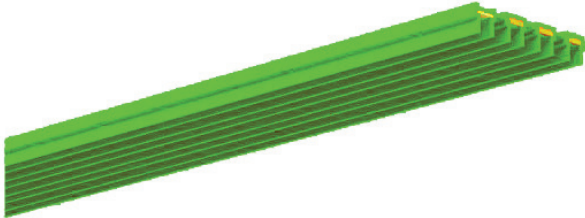

Type	Poles	Condcutor cross section (mm ²)	Max. current (A)
PCHTR4502KPA	4	4x10mm ²	50A
PCHTR4502KPA	4	3x15mm ² + 1x10mm ²	80A
PCHTR4502KPA	4	3x20mm ² + 1x10mm ²	100A
PCHTR4502KPA	4	3x25mm ² + 1x12,5mm ²	120A
PCHTR4502KPA	4	3x35mm ² + 1x15mm ²	140A

PCHTR6502KPA body (indoor only)

Rating: 6P, 690V, 50A-80A

Conductor material: cooper

Insulation jacket material: rigid PVC (heat resistance: 75°C)

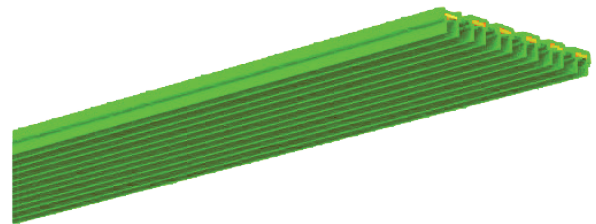

Type	Poles	Condcutor cross section (mm ²)	Max. current (A)
PCHTR6502KPA	6	6x10mm ²	50A
PCHTR6502KPA	6	6x15mm ²	80A

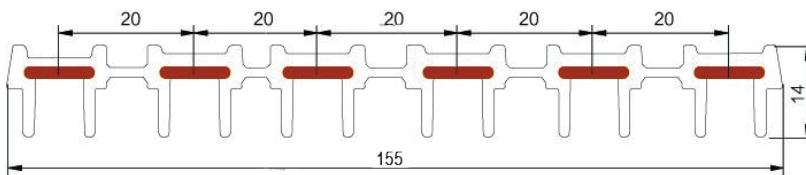

Hanger clamp

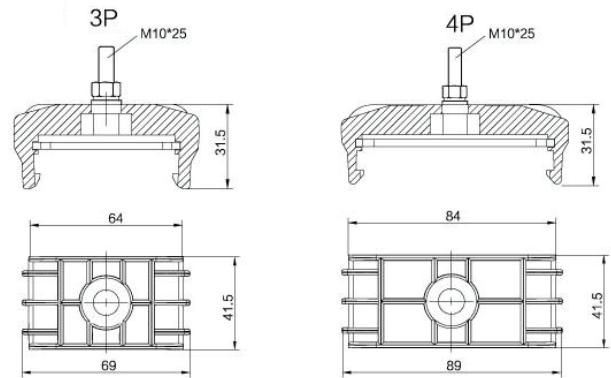
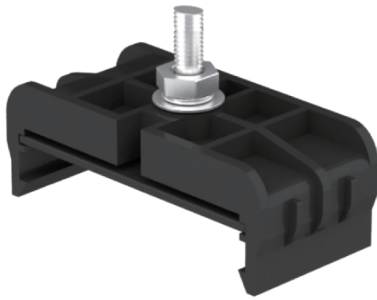

Type	Model	Weight (kg)	Material
PCHTR3HC	3P 50A-120A	0,07	Plastic
PCHTR3HC140	3P 140A	0,068	Plastic
PCHTR4HC	4P 50A-120A	0,08	Plastic
PCHTR4HC140	4P 140A	0,078	Plastic
PCHTR6HC	6P	0,098	Plastic

Joining box (line feeding)

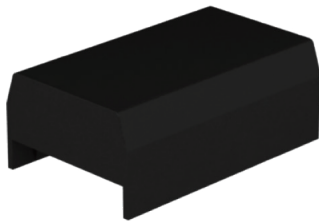

Bended joints

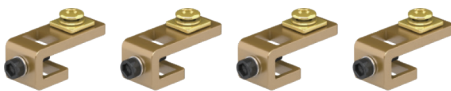

Type	Model	Rating	Weight (kg)
PCHTR3LF	3P, bended joints	3P 690V 100A	0,20
PCHTR4LF	4P, bended joints	4P 690V 100A	0,25
PCHTR6LF	6P, bended joints	6P 690V 100A	0,35

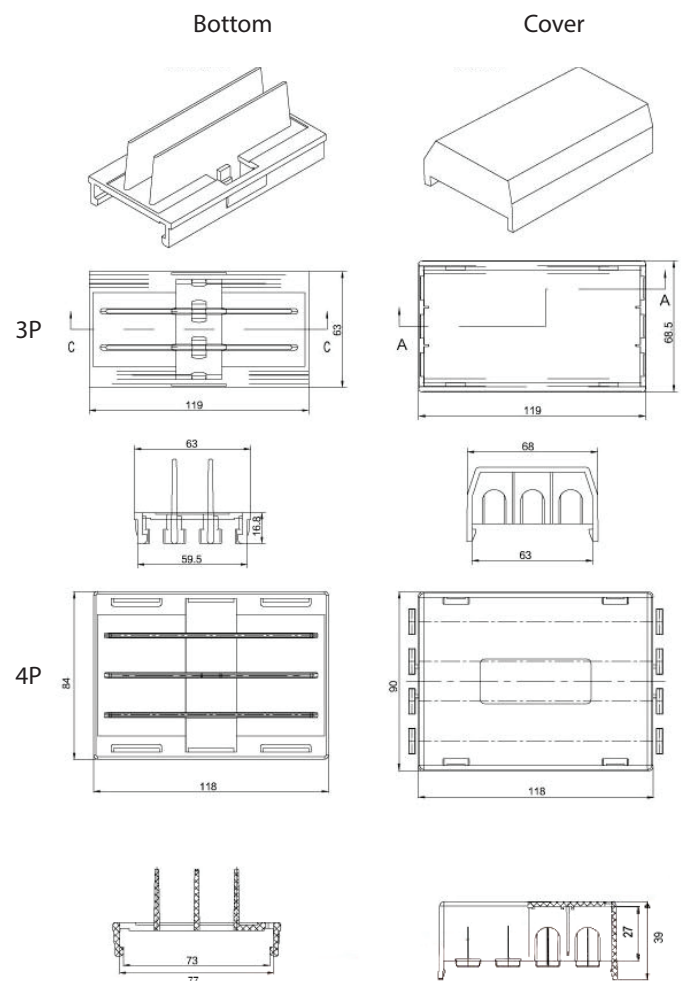

Collector



Single collector PCHTR4CC

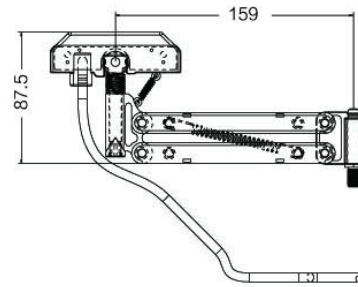

Double collector PCHTR4DCC

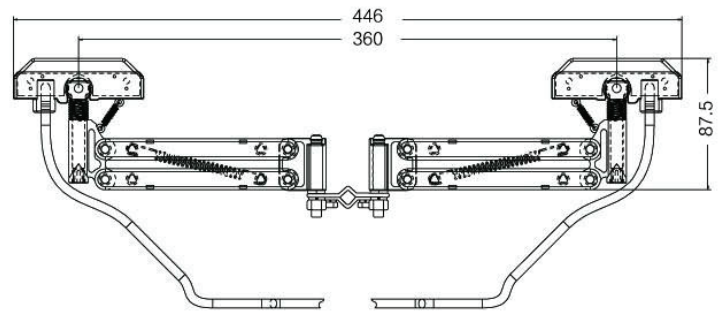

Type	Rating	Weight (kg)	Material
PCHTR4CC	690V 30A	0,16	Plastic & carbon
PCHTR4CC	690V 60A	0,17	Plastic & carbon
PCHTR4DCC	690V 120A	0,34	Plastic & carbon

Towing Bracket



Type	Model	Weight (kg)	Material
PCHTR3TB	3P	0,122	Steel
PCHTR4TB	4P	0,168	Steel

End tensioner (end feeding)

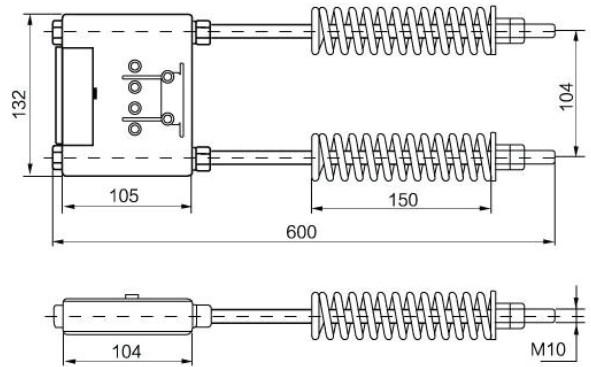
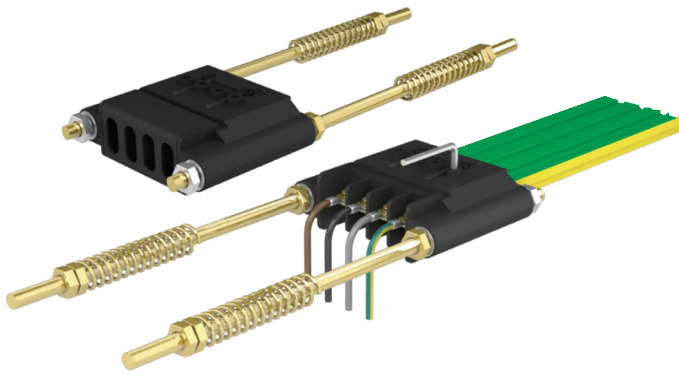

Type	Model	Rating	Weight (kg)	Remark
PCHTR3ET	3P	3P 690V 120A	1,80	Each package packed in 2 pieces
PCHTR4ET	4P	4P 690V 120A	2,15	Each package packed in 2 pieces
PCHTR6ET	6p	6P 690V 140A	2,95	Each package packed in 2 pieces

Towing arm

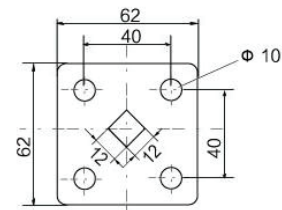
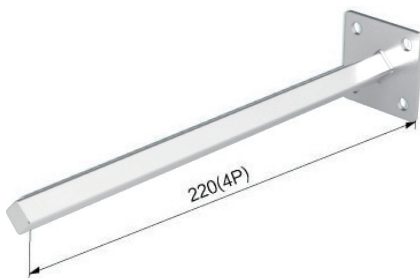

Type	Model	Weight (kg)	Material
PCHTR3TA	3P	0,58	Steel
PCHTR4TA	4P	0,65	Steel

Carbon brush

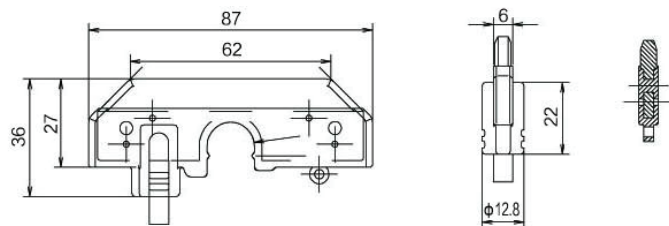

Type	Model	Weight (kg)	Material
PCHTR4CB30	For collector	0,070	Plastic & carbon
PCHTR4CB60	For collector	0,075	Plastic & carbon

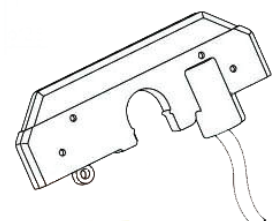

Installation Technical Parameters

The structure and layout of the hanging bracket and tighten bracket

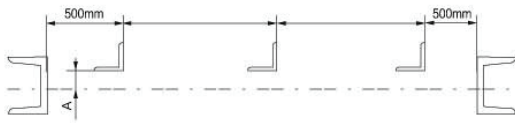

Application Range	A=20
-------------------	------

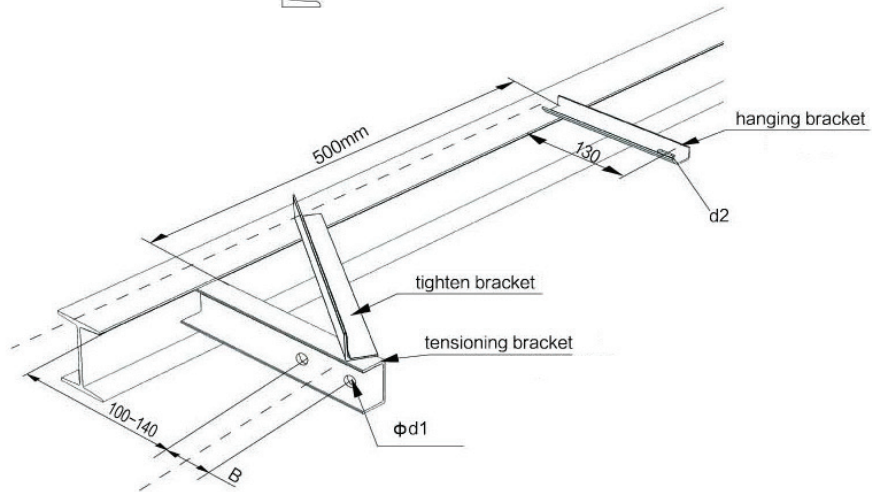

Model				
3P	84	130	11	10.5x30
4P	104	130	11	10.5x30
6P	182	130	11	10.5x30

Installation distance	Standard distance 1,2m, max distance 2m	
type of support bracket	tensioning bracket	-80, -100
	hanging bracket	tailored support bracket

Hanger installation

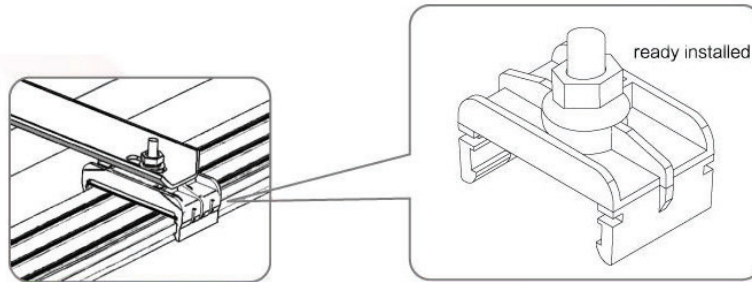

Special installation

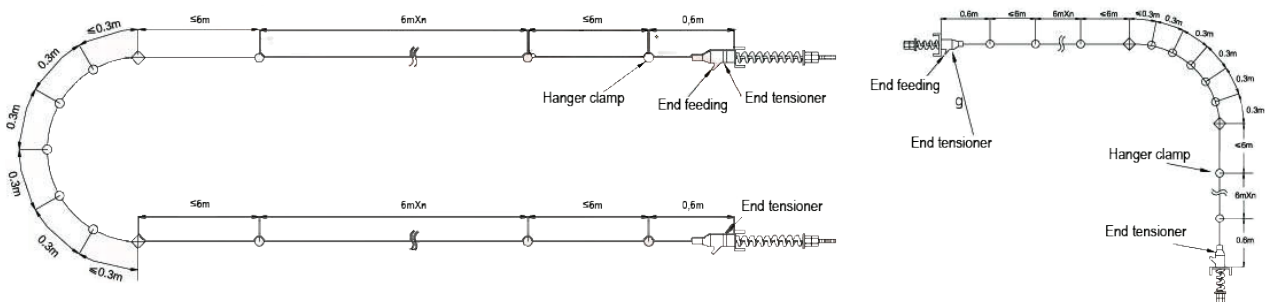

Installation of End Tensioner (End feeding)

Important notes of the installation

Ready to install

Determine the running distance between two tight brackets as shown in Figure.

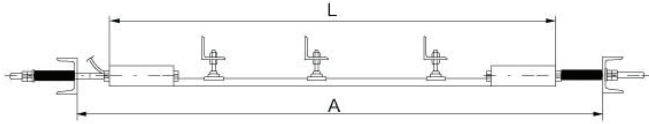

Tensioning bracket distance

A-500m

Put the conductor rail right through the tensioner, screws and tighten it.

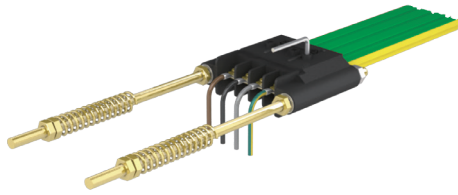

After tensioner is installed on the one end, hang the conductor rail on with a rope, and then pressed into the hanger and tighten.

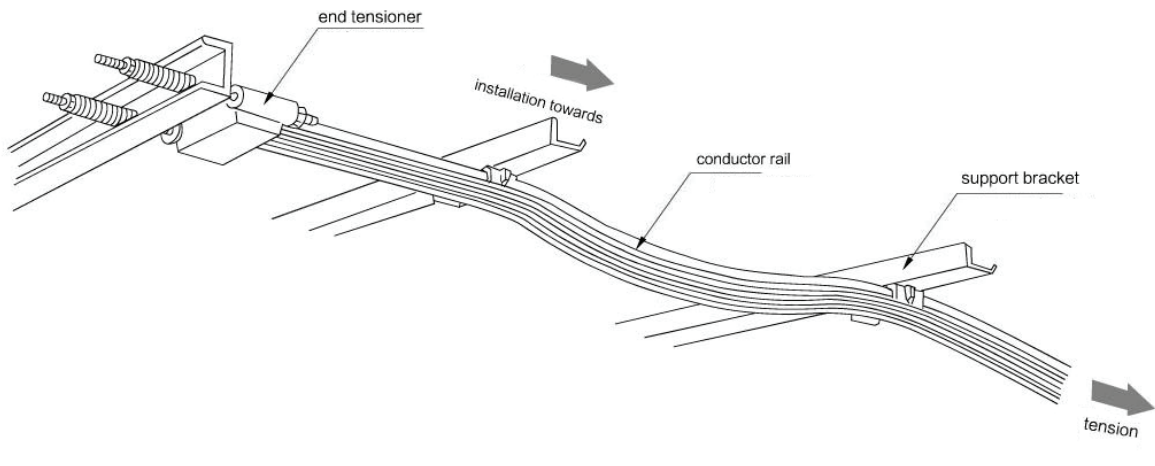

Tensioner settings

The size of the tension is related to temperature, and its size should be guaranteed to absorb the change of the conductor rail length which led to when the temperature change. For convenience of the adjustment, should calculate to determine the length of spring after compressing.

$$a=140+16.6 \times 10^3 \times (T+10) \times L \pm 15 \text{mm}$$

T: Environmental temperature when install (°C)

L: Effective length of the conductor rail (m)

Effective length of the conductor rail: 1/2 of the total length, when install spring on the ends.

Installation of Jointing Box (Line Feeding)

The installation of bend connectors

Shell stripped 30mm, bend the Copper belt 90° via pliers, insert it into the jointing box and tighten the screws. The jointing box can be used for power supply.

After stripping the conductor rail shell which need to connect, to insert the copper strips into dedicated joint, and then 90 degrees bending, bending of the standard 3cm in height and be limited to 3.5cm, and then tighten the screws. If power needed, screw the connect cable joint directly on the screw as shown in Figure, then drill on the top of the jointing box cover, and install waterproof cable connector, drag the lead out cable out of the waterproof joints. Tip: The screws must be fully tightened.

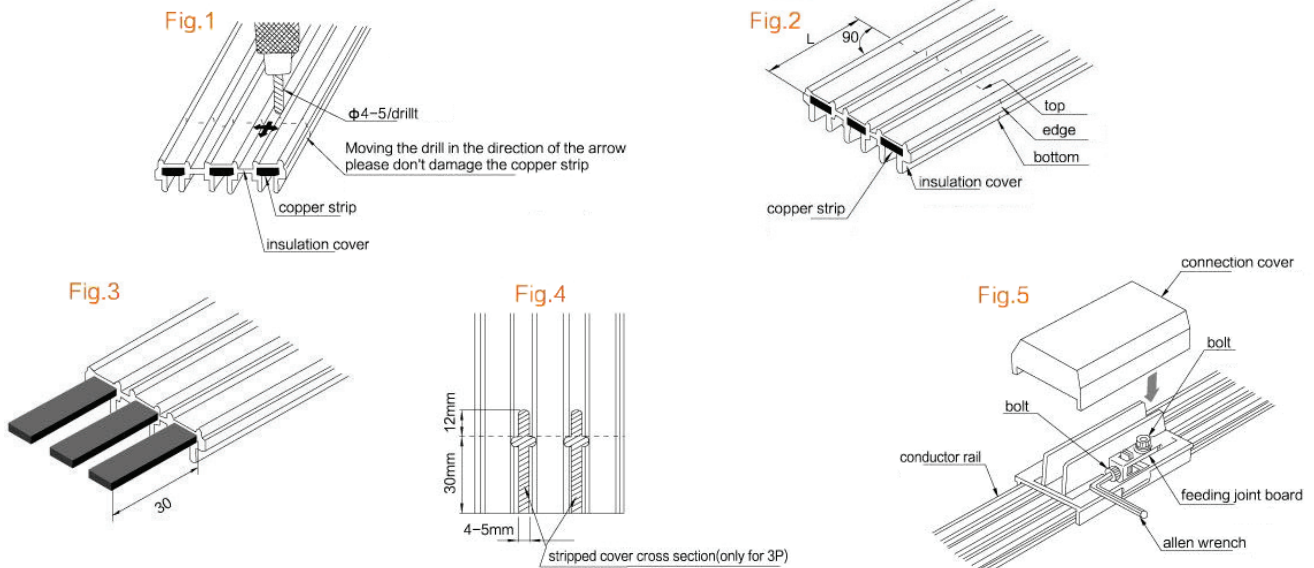

Installation of Collector

a. The installation of the current collector: Define the length of the tractor unit according to the amount of electrode and installation space. 70 ± 5 mm distance should be ensured in distance between the upper end and down end of the conductor rail, it is only natural that support arm parallel to the slip line when the collector installed.(refer to the installation drawing of the conductor rail for more detail). b. Inspection: Inspect the depth of parallelism between the conductor rail and operation guide of the hoisting unit and control the depth within 20mm, make a test run and check the running state of the flake passing through each nodal point, tighten all the fastening piece if some problems occurs, dry run one month without interval and tighten all fastening pieces again.

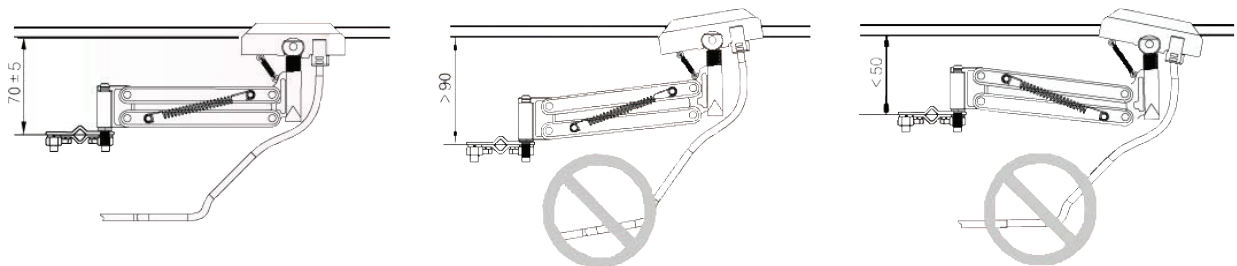



EMS
Electro Mechanical Solutions

www.ems-sl.com